



# UK1 and UKR1 series

M18 cylindrical direct diffuse & retro-reflective Ultrasonic Sensor UK1 with Teach-In button



## features

- Models with digital programmable output
- Models with current or voltage analogue outputs
- Adjustable Hysteresis function: model with programmable double digital outputs, specific for levels
- Working area adjusting (window teach or single point teach) by Teach-in button suitable for all models for a fast coming into work
- Multifunction LED indicator: output type, adjustment procedure, NO/NC selection and reverse analog output slope



M18 with Teach-In button

## web contents



- Application notes
- Photos
- Catalogue / Manuals



## code description (\*)

UK 1 A / E 1 - 0 E UL AN

	UK	1	A	/	E	1	-	0	E	UL	AN	
series	UK	M18 Ultrasonic Sensor										
function		Direct diffuse models										
	R	Retroreflective models										
housing type	1	Standard housing										
nominal sensing distance Sn	A	50 - 400 mm (100 - 400 mm retroreflective models)										
	C	100 - 900 mm (150 - 800 mm retroreflective models)										
	D	150 - 1,600 mm (plastic models) / 200 - 1,500 mm (metallic models) (200 - 1,600 mm retroreflective models)										
	F	200 - 2,200 mm (250 - 2,000 mm retroreflective models)										
adjustment	E	Adjustment by Teach-In button										
output	1	0...10 V single voltage analogue output										
	2	4...20 mA single current analogue output										
	4	NPN - NO/NC digital output + 4 ... 20 mA current analogue output										
	6	PNP - NO/NC digital output + 4 ... 20 mA current analogue output										
	7	PNP - NO/NC digital output + 0 ... 10 V voltage analogue output										
	9	NPN - NO/NC digital output + 0 ... 10 V voltage analogue output										
	N	NPN - NO/NC single digital output										
	P	PNP - NO/NC single digital output										
	M	NPN - two digital outputs with standard window and adjustable hysteresis functions										
housing materials	0	Plastic housing										
	1	AISI 316L (DIN 1.4404) stainless steel housing (axial)										
	2	90° emission, plastic housing										
cable exit / connector	A	Axial cable exit (2 m)										
	E	M12 plug cable exit										
cULus	UL	With cULus certification										
ATEX	AN	ATEX certified, Cat.3 2.22 Zone										

(\*) Multiplexing models and with synchronization available.

## available models

single digital output standard cULus certified available models

housing	distance (mm)	output	analogue output 0...10 V	analogue output 4...20 mA	1 x PNP - NO/NC	1 x NPN - NO/NC
plastic	50...400	M12 connector	UK1A/E1-0EUL	UK1A/E2-0EUL	UK1A/EP-0EUL	UK1A/EN-0EUL
	100...900		UK1C/E1-0EUL	UK1C/E2-0EUL	UK1C/EP-0EUL	UK1C/EN-0EUL
	150...1,600		UK1D/E1-0EUL	UK1D/E2-0EUL	UK1D/EP-0EUL	UK1D/EN-0EUL
	200...2,200		UK1F/E1-0EUL	UK1F/E2-0EUL	UK1F/EP-0EUL	UK1F/EN-0EUL
	50...400	cable	UK1A/E1-0AUL	UK1A/E2-0AUL	UK1A/EP-0AUL	UK1A/EN-0AUL
	100...900		UK1C/E1-0AUL	UK1C/E2-0AUL	UK1C/EP-0AUL	UK1C/EN-0AUL
	150...1,600		UK1D/E1-0AUL	UK1D/E2-0AUL	UK1D/EP-0AUL	UK1D/EN-0AUL
	200...2,200		UK1F/E1-0AUL	UK1F/E2-0AUL	UK1F/EP-0AUL	UK1F/EN-0AUL

## available models

double digital output standard cULus certified available models

housing	distance (mm)	output	2 x PNP - NO/NC	2 x NPN - NO/NC
plastic	50...400	M12 connector	UK1A/EW-0EUL	UK1A/EM-0EUL
	100...900		UK1C/EW-0EUL	UK1C/EM-0EUL
	150...1,600		UK1D/EW-0EUL	UK1D/EM-0EUL
	200...2,200		UK1F/EW-0EUL	UK1F/EM-0EUL
	50...400	cable	UK1A/EW-0AUL	UK1A/EM-0AUL
	100...900		UK1C/EW-0AUL	UK1C/EM-0AUL
	150...1,600		UK1D/EW-0AUL	UK1D/EM-0AUL
	200...2,200		UK1F/EW-0AUL	UK1F/EM-0AUL
stainless steel AISI 316L	50...400	M12 connector	UK1A/EW-1EUL	UK1A/EM-1EUL
	100...900		UK1C/EW-1EUL	UK1C/EM-1EUL
	200...1,500		UK1D/EW-1EUL	UK1D/EM-1EUL
	50...400		UK1A/EW-1AUL	UK1A/EM-1AUL
	100...900	cable	UK1C/EW-1AUL	UK1C/EM-1AUL
	200...1,500		UK1D/EW-1AUL	UK1D/EM-1AUL

## available models

analog and digital output cULus certified

housing	distance (mm)	output	1 x PNP - NO/NC + 1 x 4...20 mA	1 x NPN - NO/NC + 1 x 4...20 mA	1 x PNP - NO/NC + 1 x 0...10 V	1 x NPN - NO/NC + 1 x 0...10 V
plastic	50...400	M12 connector	UK1A/E6-0EUL	UK1A/E4-0EUL	UK1A/E7-0EUL	UK1A/E9-0EUL
	100...900		UK1C/E6-0EUL	UK1C/E4-0EUL	UK1C/E7-0EUL	UK1C/E9-0EUL
	150...1,600		UK1D/E6-0EUL	UK1D/E4-0EUL	UK1D/E7-0EUL	UK1D/E9-0EUL
	200...2,200		UK1F/E6-0EUL	UK1F/E4-0EUL	UK1F/E7-0EUL	UK1F/E9-0EUL
	50...400	cable	UK1A/E6-0AUL	UK1A/E4-0AUL	UK1A/E7-0AUL	UK1A/E9-0AUL
	100...900		UK1C/E6-0AUL	UK1C/E4-0AUL	UK1C/E7-0AUL	UK1C/E9-0AUL
	150...1,600		UK1D/E6-0AUL	UK1D/E4-0AUL	UK1D/E7-0AUL	UK1D/E9-0AUL
	200...2,200		UK1F/E6-0AUL	UK1F/E4-0AUL	UK1F/E7-0AUL	UK1F/E9-0AUL
stainless steel AISI 316L	50...400	M12 connector	UK1A/E6-1EUL	UK1A/E4-1EUL	UK1A/E7-1EUL	UK1A/E9-1EUL
	100...900		UK1C/E6-1EUL	UK1C/E4-1EUL	UK1C/E7-1EUL	UK1C/E9-1EUL
	200...1,500		UK1D/E6-1EUL	UK1D/E4-1EUL	UK1D/E7-1EUL	UK1D/E9-1EUL
	50...400		UK1A/E6-1AUL	UK1A/E4-1AUL	UK1A/E7-1AUL	UK1A/E9-1AUL
	100...900	cable	UK1C/E6-1AUL	UK1C/E4-1AUL	UK1C/E7-1AUL	UK1C/E9-1AUL
	200...1,500		UK1D/E6-1AUL	UK1D/E4-1AUL	UK1D/E7-1AUL	UK1D/E9-1AUL



## available models

cULus and ATEX certified

housing	distance (mm)	output	analogue output 0...10 V	analogue output 4...20 mA	1 x PNP - NO/NC	1 x NPN - NO/NC + 1 x 4...20 mA	1 x PNP - NO/NC + 1 x 0...10 V
plastico	50...400	M12 connector	UK1A/E1-0EULAN	UK1A/E2-0EULAN	UK1A/EP-0EULAN	UK1A/E6-0EULAN	UK1A/E7-0EULAN
	100...900		UK1C/E1-0EULAN	UK1C/E2-0EULAN	UK1C/EP-0EULAN	UK1C/E6-0EULAN	UK1C/E7-0EULAN
	150...1.600		UK1D/E1-0EULAN	UK1D/E2-0EULAN	UK1D/EP-0EULAN	UK1D/E6-0EULAN	UK1D/E7-0EULAN
	200...2.200		UK1F/E1-0EULAN	UK1F/E2-0EULAN	UK1F/EP-0EULAN	UK1F/E6-0EULAN	UK1F/E7-0EULAN

## technical specifications

cULus certified models

	UK1A/E*-**UL	UK1C/E*-**UL	UK1D/E*-**UL	UK1F/E*-**UL
				
maximum sensing distance	400 mm <sup>(1)</sup>	900 mm <sup>(2)</sup>	1,600 mm <sup>(2)</sup> 1,500 mm <sup>(2)</sup>	2,200 mm <sup>(2)</sup>
minimum sensing distance	50 mm	100 mm	150 mm 200 mm	200 mm
sensing range (Sd)	50...400 mm	100...900 mm	150...1,600 mm 200...1,500 mm	200...2,200 mm
beam angle	± 8° / ± 7°	± 7°	± 8° / ± 7°	± 7°
switching frequency (digital output)	10 Hz	4 Hz	2 Hz / 1Hz	1 Hz
response time (digital output)	500 ms	≤125 ms	250 ms / 500 ms	500 ms
hysteresis	1%			
repeatability	0.5%			
resolution	1 mm	2 mm	3 mm	3 mm
linearity error	1%			
temperature range	- 20°C...+ 60°C			
temperature compensation	●			
operating voltage	15 - 30 Vcc			
temperature drift	5%			
ripple	≤ 7%			
leakage current	10 µA @ 30 Vcc			
output voltage drop	2.2 V max. (IL = 100 mA)			
no-load supply current	≤ 50 mA			
output current (digital output)	100 mA <sup>(3)</sup>			
minimum load resistance (analog voltage output)	3 k Ω			
set point adjustment	Teach-In button			
power on delay	≤ 500 ms (digital output) ≤ 900 ms (analogue output)			
power supply protections	polarity reversal, transient			
digital output protections	short circuit (auto reset), overvoltage pulses			
analogical electrical protections	overvoltage pulses			
EMC	conforming to EMC Directive, according to EN 60947-5-2			
protection degree	IP67 (EN60529) <sup>(4)</sup>			
housing material	PBT/stainless steel AISI 316L			PBT
active head material	Epoxy-Glass resin			
tightening torque	1 Nm plastic housing / 50 metallic housing			1 Nm
weight	plastic version: 70 g connector / 110 g cable metallic version: 100 g connector / 170 gr cable			
storage temperature	- 35°C...+ 70° without freezing			

(1) Metallic target 100 x 100 mm (2) Metallic target 200 x 200 (3) Available models without cULus certified with output current: 500 mA (models with single or double digital output); 300 mA (models with digital and analog output) (4) Protection guarantee only with plug cable well mounted



M18 with  
Teach-In button

UK1 - UKR1



## available models

### retroreflective models

housing	distance (mm)	output	material	PNP - NO/NC	NPN - NO/NC
M18	100...400	M12	plastic	UKR1A/EP-0EUL	UKR1A/EN-0EUL
	150...800			UKR1C/EP-0EUL	UKR1C/EN-0EUL
	200...1,600			UKR1D/EP-0EUL	UKR1D/EN-0EUL
	250...2,000			UKR1F/EP-0EUL	UKR1F/EN-0EUL
	100...400	cable		UKR1A/EP-0AUL	UKR1A/EN-0AUL
	150...800			UKR1C/EP-0AUL	UKR1C/EN-0AUL
	200...1,600			UKR1D/EP-0AUL	UKR1D/EN-0AUL
	250...2,000			UKR1F/EP-0AUL	UKR1F/EN-0AUL

## technical specifications

### retroreflective models

	UKR1A/E*-*E	UKR1C/E*-*E	UKR1D/E*-*E	UKR1F/E*-*E
nominal sensing distance	400 mm	800 mm	1,600 mm	2,000 mm
reflector minimum sensing distance	100 mm	150 mm	200 mm	250 mm
beam angle	±8°	±7°	±8°	±7°
switching frequency	8 Hz	3 Hz	1 Hz	1 Hz
operating voltage	15...30 Vdc			
max. ripple content	5%			
output type	PNP or NPN NO/NC selectable			
output current	100 mA			
output voltage drop	≤ 2.2 V (@ I = 100mA)			
no-load supply current	≤ 50 mA @ Val=24V			
leakage current	≤ 10 µA @ 30V			
power on delay	≤ 500 ms			
ambient temperature range	- 20°C...+ 60°C			
temperature drift of Sr	≤ 5 %			
short-circuit protection	● (autoreset)			
induction protection	●			
voltage reversal protection	●			
weight	26 g			
LEDs	yellow: exit			
protection degree	IP67			
EMC	IEC60947-5-2			
housing material	plastic housing PBT			
active head material	glass resin			
connection	M12 plug cable exit			
weight	70 g connector / 100 g cable			

## available models

### 90° emission models

housing	portata (mm)	output	material	PNP - NO/NC 0...10 V	NPN - NO/NC 0...10 V	PNP - NO/NC 4...20 mA	NPN - NO/NC 4...20 mA	2 x PNP hysteresis/window	2 x NPN hysteresis/window
M18	50...400	M12	plastic	UK1A/E7-2EUL	UK1A/E9-2EUL	UK1A/E6-2EUL	UK1A/E4-2EUL	UK1A/EW-2EUL	UK1A/EM-2EUL
	150...1.600			UK1D/E7-2EUL	UK1D/E9-2EUL	UK1D/E6-2EUL	UK1D/E4-2EUL	UK1D/EW-2EUL	UK1D/EM-2EUL
	200...2.200			UK1F/E7-2EUL	UK1F/E9-2EUL	UK1F/E6-2EUL	UK1F/E4-2EUL	UK1F/EW-2EUL	UK1F/EM-2EUL



M18 with  
Teach-In button

## technical specifications

### 90° emission models

	UK1A/E*-2EUL	UK1D/E*-2EUL	UK1F/E*-2EUL
nominal sensing distance	400 mm	1,600 mm	2,200 mm
minimum sensing distance	50 mm	150 mm	200 mm
sensing range	50...400 mm	150...1,600 mm	200...2,200 mm
beam angle	± 8°	± 8°	± 7°
hysteresis	1%		
repeatability	0.5%		
switching frequency	10 Hz	2 Hz	1 Hz
response time	500 ms		
operating voltage	15...30 Vdc		
max. ripple content	7%		
output current	100 mA (digital output)		
output voltage drop	≤ 2.2 V (@ I = 100mA)		
no-load supply current	≤ 50 mA		
leakage current	≤ 10 µA @ 30V		
power on delay	≤ 900 mA		
ambient temperature range	- 20°C...+ 60°C		
temperature drift of Sr	≤ 5%		
short-circuit protection	● (autoreset)		
induction protection	●		
voltage reversal protection	●		
weight	75 g		
LEDs	green: echo - yellow: output		
protection degree	IP67		
housing material	plastic housing: PBT		
active head material	glass reinforced epoxy resin		
connection	M12 plug cable exit		

UK1 - UKR1



M18 with Teach-In button

# electrical diagrams of connections

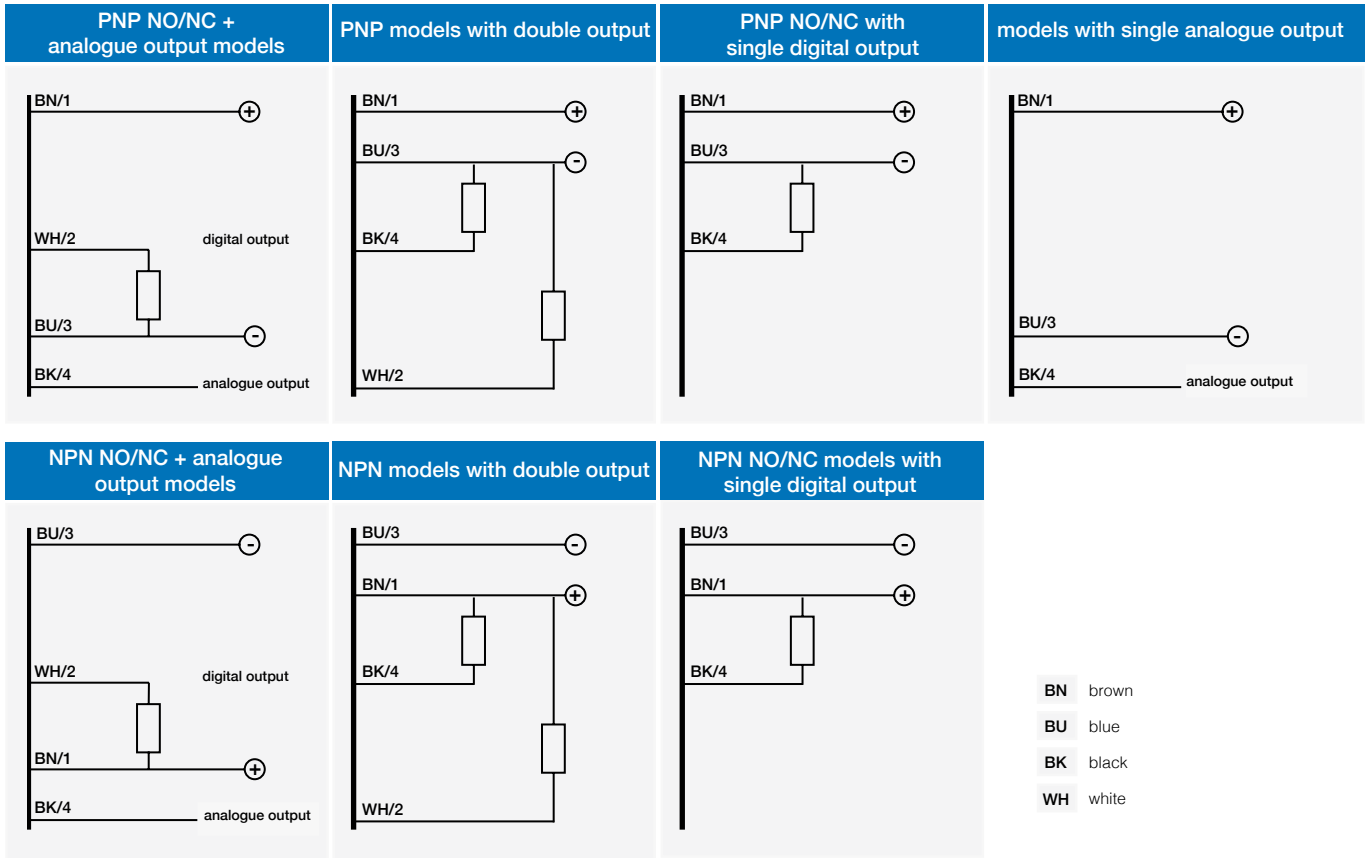

# connectors

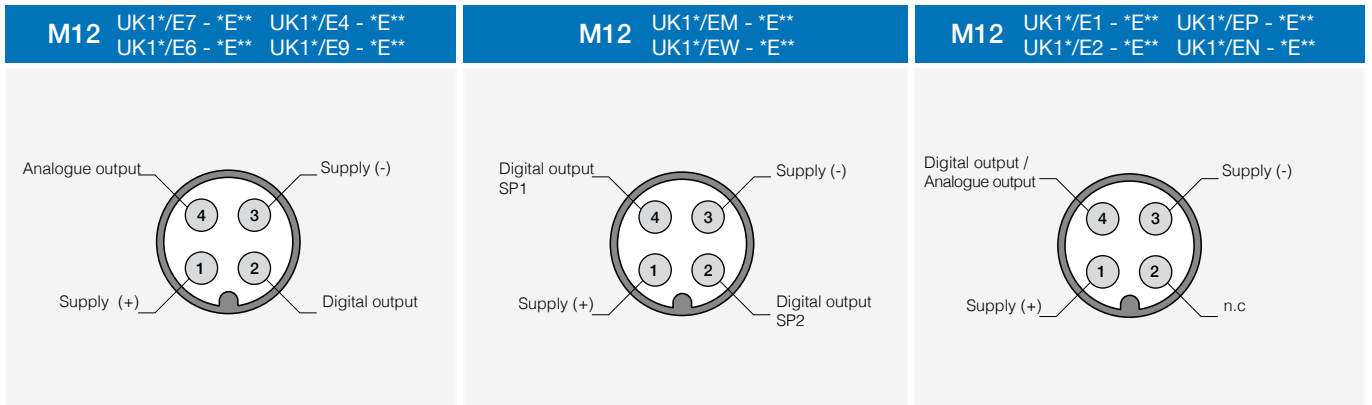

models with single digital output

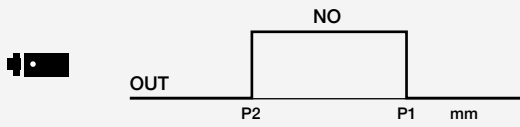

models with single analogue output

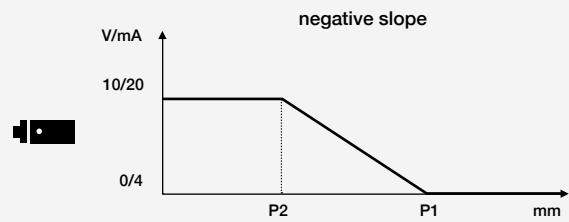
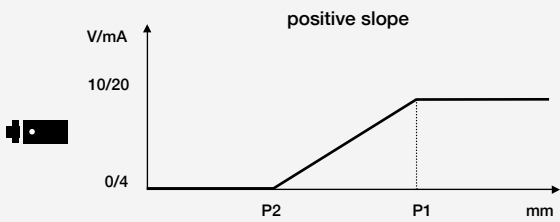

models with double digital output - standard window and adjustable hysteresis outputs

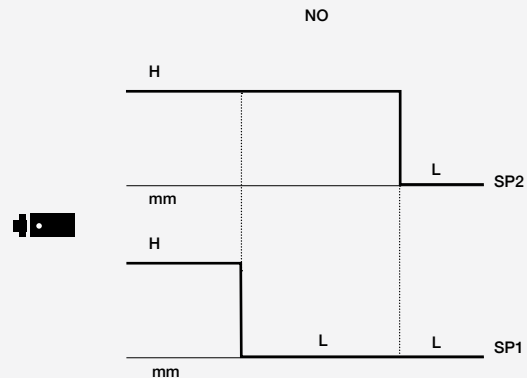
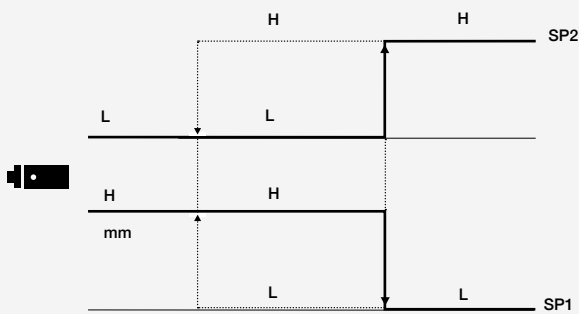

models with digital output + analogue output <sup>(1)</sup>

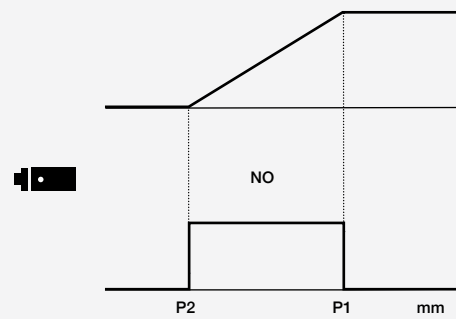
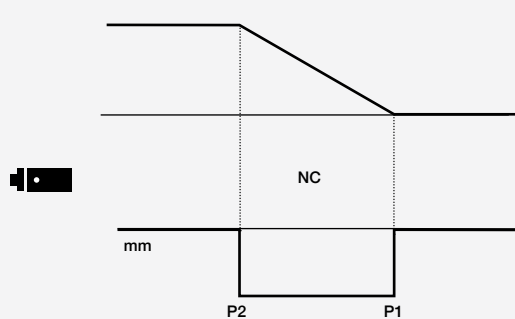

<sup>(1)</sup> It can be used as a single model output

- P1** maximum selected working distance and first point to select
- P2** minimum selected working distance and second point to select



# response diagrams

direct diffuse models

M18 with Teach-In button

UK1A/\*\*-\*\* parallel displacement

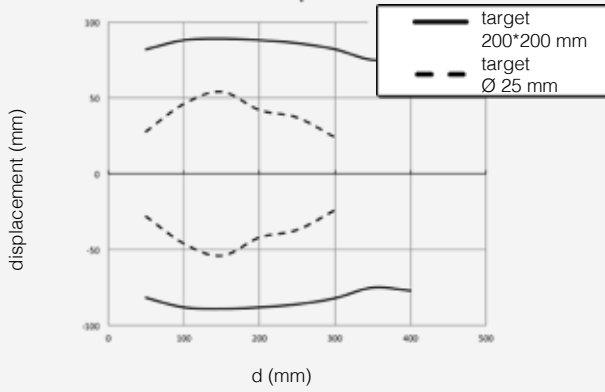

UK1C/\*\*-\*\* parallel displacement

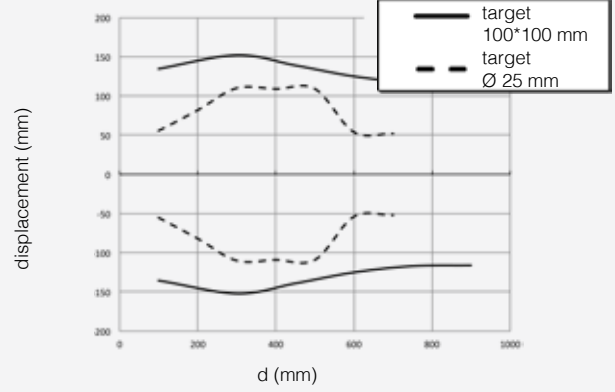

UK1D/\*\*-\*\* parallel displacement

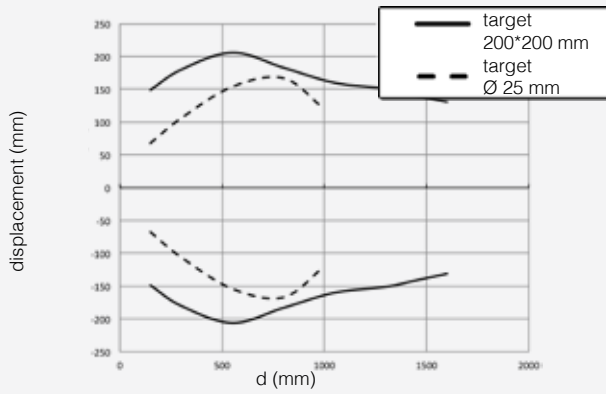

UK1F/\*\*-\*\* parallel displacement

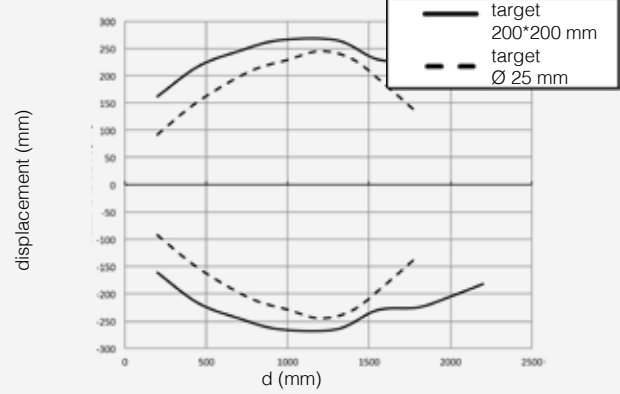



# response diagrams

retroreflective models



M18 with Teach-In button

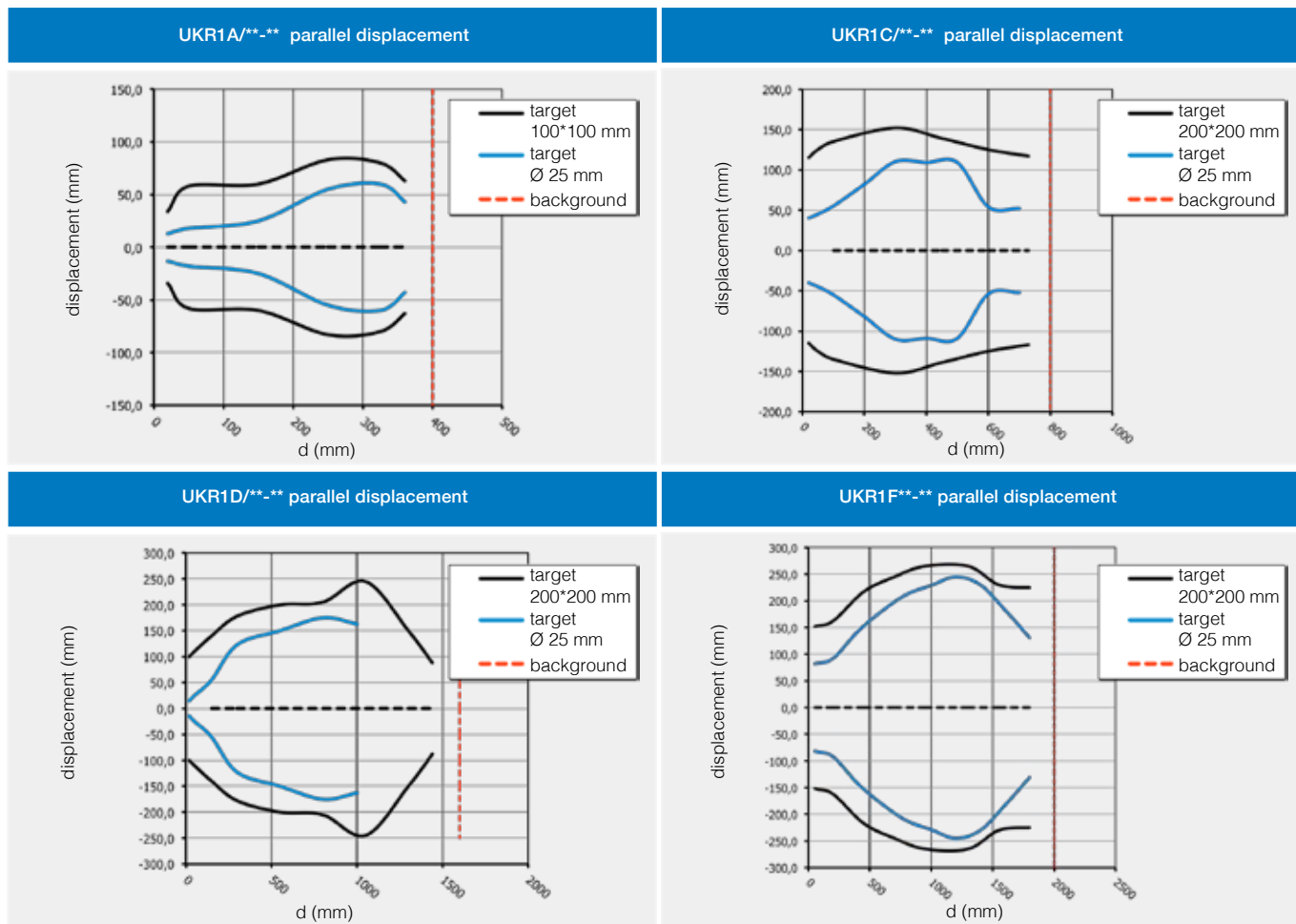

# dimensions (mm)

plastic models

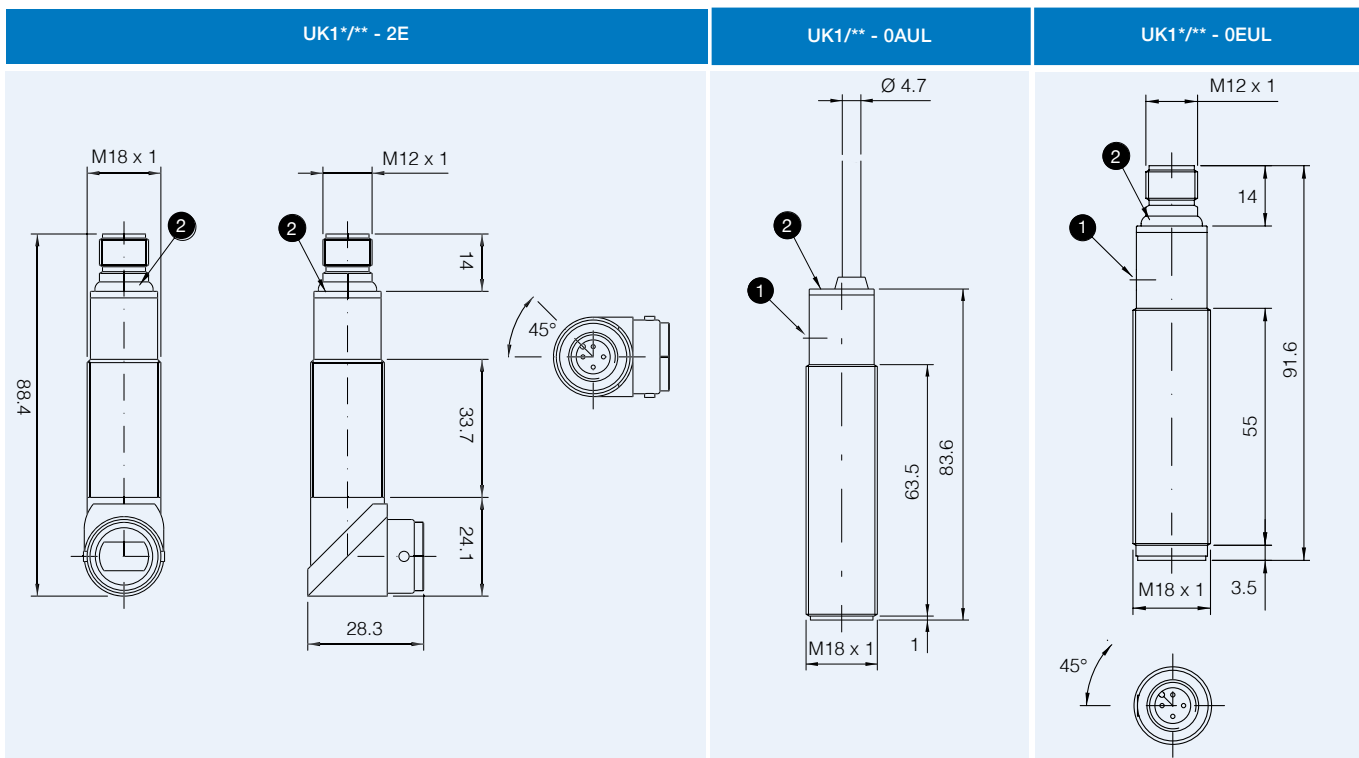

1 Teach-In button

2 LED

UK1 - UKR1



## dimensions (mm)

accessories included in all plastic models

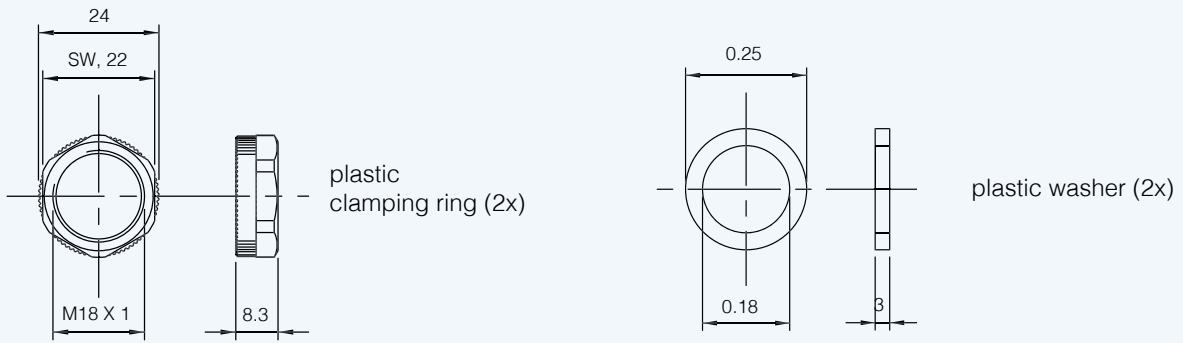

M18 with  
Teach-In button

## dimensions (mm)

metallic models

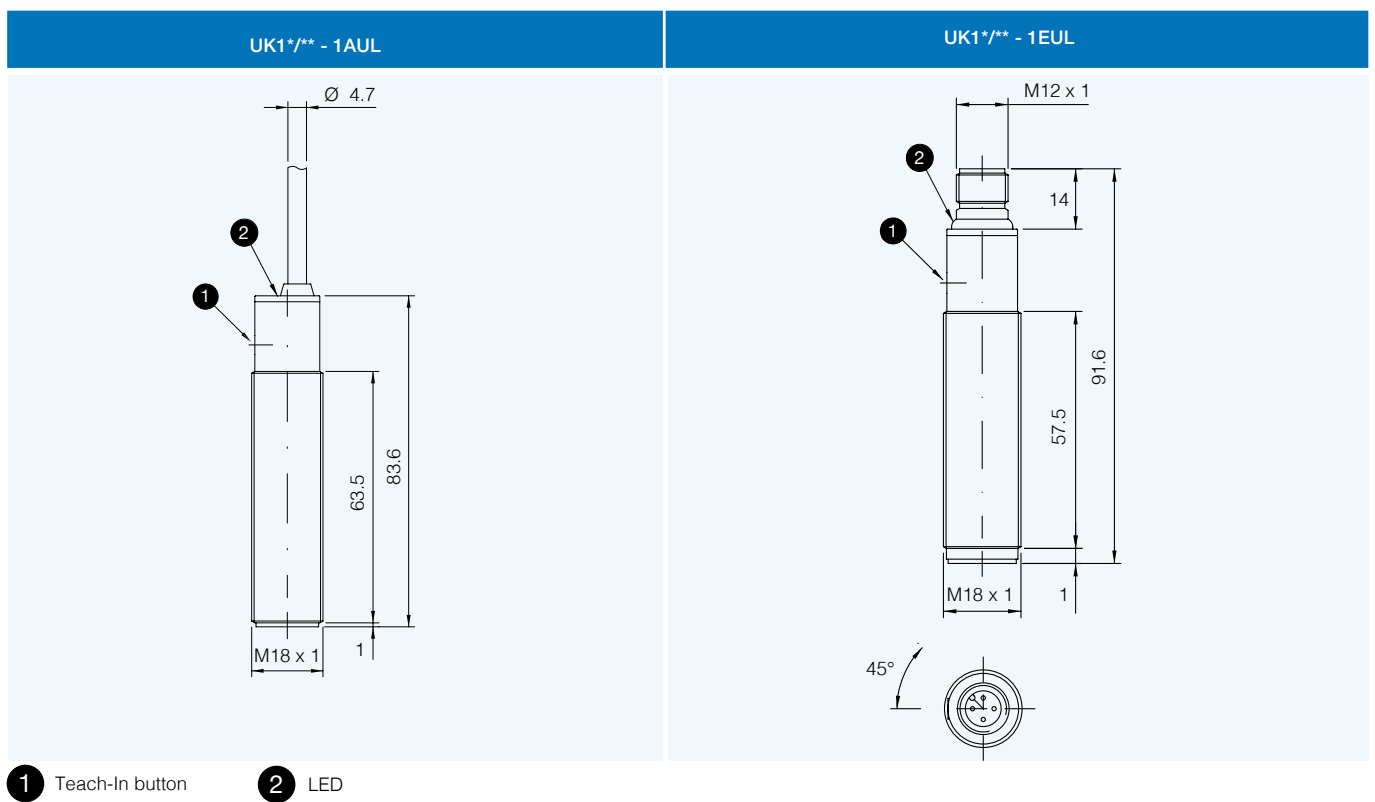

## dimensions (mm)

accessories included in all metallic models

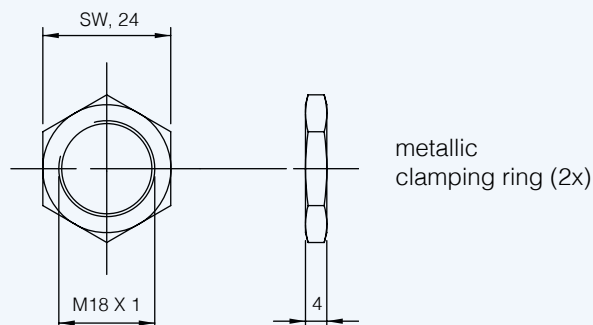

UK1 - UKR1